

# Series 774 Automatic Skid Package

Fluid Engineering | 1432 Walnut St | Erie, PA 16502 USA  
PH 814.453.5014 | FAX 814.452.6573 | [www.fluideng.com](http://www.fluideng.com) | [sales@fluideng.com](mailto:sales@fluideng.com)



## STANDARD DESIGN

Two complete Fluid Engineering ELIMINATOR® 753 Automatic Strainers. Skid assembly is a steel I-Beam construction. Sequence Control Package including a NEMA 4 Enclosed Panel, Electronic Backwash Valve for each strainer, and Dual Element Differential Pressure switch also for each strainer.

## APPLICATION

The Eliminator's® patented unique strainer element design permits installation in virtually any piping system operating at a positive pressure.

The Eliminators® can operate through a wide range of operating pressures (10 psig minimum) and solids loading with effective debris removal and backwashing across the entire pressure range. Additionally, only one drain/backwash connection is required for installation effectively eliminating the expense of a separate backwash connection.

Strainers are used to protect equipment such as valves, pumps, meters, heat exchangers, or spray nozzles, as well as in feed water and process water applications or virtually any similar application.

## CONTINUOUS FLOW

The Fluid Engineering 774 Strainer Package is designed to handle a consistent flow of debris laden influent. The dual strainer design offers a unique design in that it allows a continuous cleaning without interruption for extremely long periods of time. The single Fluid Engineering Automatic Strainer offers continuous debris removal and uninterrupted flow, having two units in one package eliminates any problems that may occur due to natural mechanical failure or fatigue. If one unit requires any sort of maintenance the flow continues through the unit in operation.

## PLUG AND PLAY

The completely assembled unit also offers the ability to virtually "Plug and Play". The package is set in place, attached to the application inlet, outlet, backwash, and drain, power wired to the control package, and the equipment is ready for full operation literally saving thousands of dollars in construction and assembly costs.

## PROVEN FEATURES INCLUDE

- Patented rugged screen and mechanical assist backwash mechanism extends useful service life.
- Unique clog-resistant straining element reduces maintenance downtime.
- Unique adjustable accelerator plate aids cleaning in difficult applications.
- All internal replacement parts supplied in corrosion resistant material.
- Efficient proven design reduces maintenance requirements; requires fewer parts.
- Flats for manual operation in case of power failure.
- Low rpm backwash mechanism provides more efficient cleaning, less wear of internals.



# Series 774 Automatic Skid Package

## How the 753 Eliminator® works

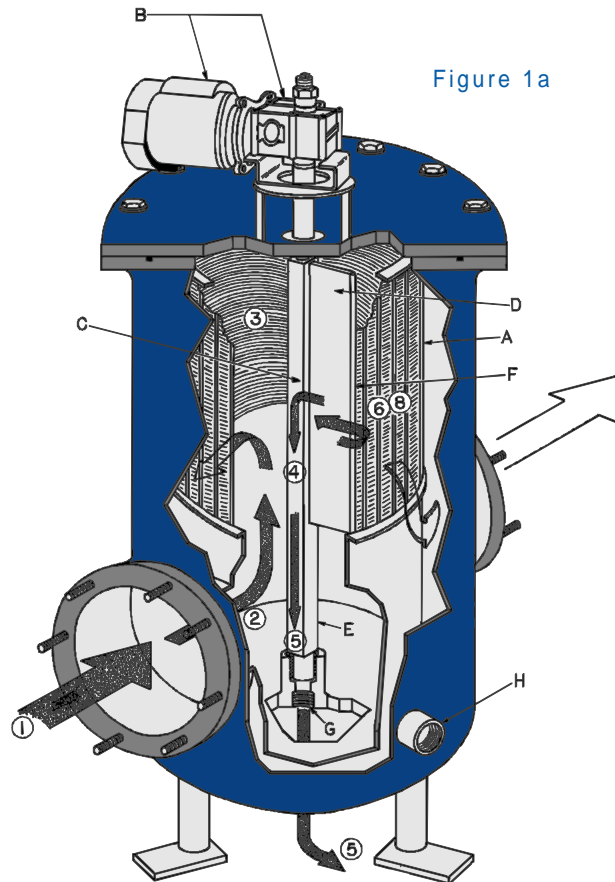

Figure 1a

1. Debris laden fluid enters through inlet to inner chamber (Figure 1a).
2. Dirty fluid flows upward to the strainer element (A).
3. Debris is retained on the flat face of the strainer element, while stained fluid continues to outer chamber and exits through strainer outlet (See Figure 1a).
4. During backwash or cleaning cycle, the motor/gear reducer (B) is engaged and drives the hollow drive shaft (C) and hollow port (D) around the inner circumference of the strainer element.
5. The backwash assembly C, D, and E are opened to atmospheric pressure by opening the backwash control valve (not shown).
6. Flow reversal occurs at the port/straining element (F) interface because of the pressure differential described in 5 (See Figure 1b).
7. Debris is effectively vacuumed from the full length of the straining element by a vigorous reverse fluid flow and into the hollow port; down the hollow drive shaft and out the backwash outlet (G).
8. The hollow port continues to sweep the full length of the strainer until the cleaning cycle has ended.
9. A brush molded to the port shoe facilitates debris removal on the straining element (See Figure 1c). A non-brush port shoe is available as an option.
10. The strainer will provide continuous uninterrupted fluid flow during the cleaning operation.
11. The cleaning cycle can be set for continuous or intermittent backwash.

U.S. Patent No. 4,818,402

Canadian Patent No. 1,314,235

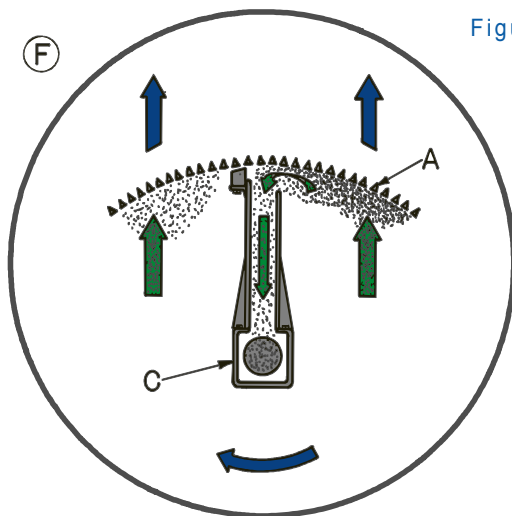

Figure 1b

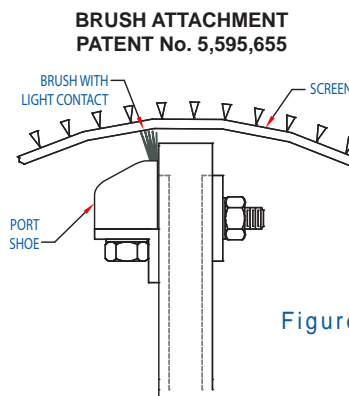

Figure 1c

# Series 774 Automatic Skid Package



## Series753 Cast Automatic Strainer

### ENGINEERED FOR EXCELLENCE

Fluid Engineering had this in mind when we designed our Series 753 Cast Self-Cleaning Strainers (Fig. 2). The priority to make quality and economy inherent in the Series 753 was Fluid Engineering's obligation to meet our customer's growing needs.

### QUALITY

Fluid Engineering Strainers have always been meticulously manufactured with quality in mind. The Fluid Engineering Series753 Cast Self-Cleaning Strainers will continue that important tradition of providing consistent and trouble-free service. They are designed and constructed to be in compliance with ANSI and ASME Section VIII, Division 1 standards.



Figure 2



### SERIES753 PRESSURE DROP P.S.I. WITH 1/32" OR LARGER SCREEN OPENING

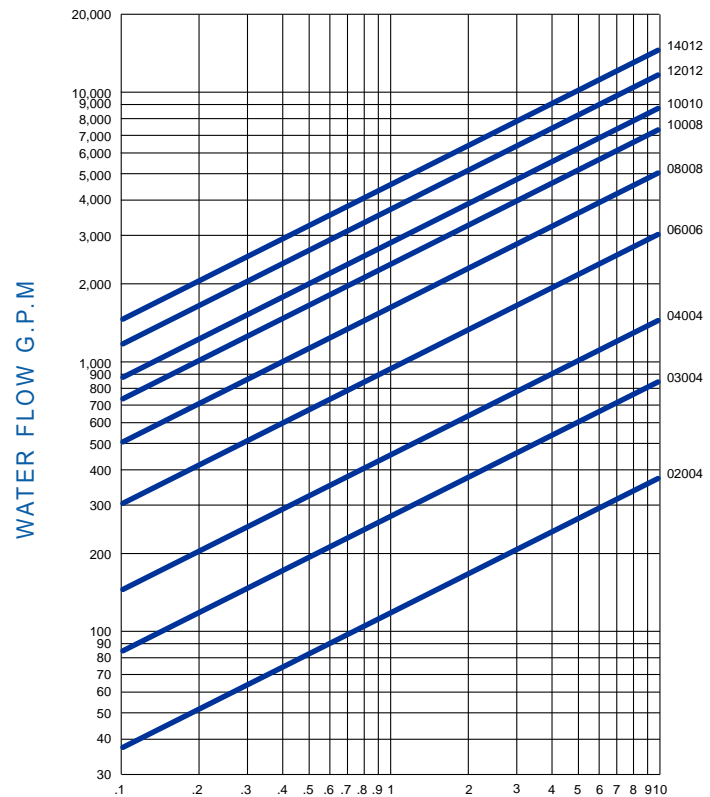



# Series 774 Automatic Skid Package

## Straining Element

The Eliminator® features a revolutionary reverse rolled wedge-wire straining element (Figure 3) that is extremely rugged and more clog resistant than conventional strainer elements that use perforated plate or wire mesh screens.

This proven state-of-the-art straining media is fabricated by wrapping vertical rods with wedge shaped profile wire. Each intersection of rod and wire is welded to produce an extremely rugged one-piece element. This forms a continuous slot that allows only two-point contact with debris particles to reduce clogging.

The wedge shaped profile wire reduces the possibility of retaining debris smaller than the screen opening which historically has been the cause of premature clogging or failure of competitive screen designs.

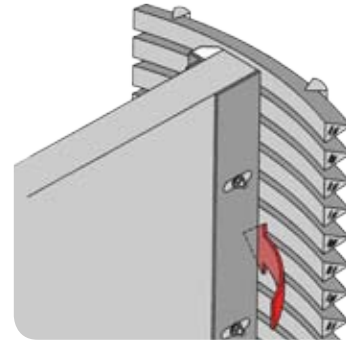

Figure 3 - Wedge Wire Straining Element Cross-Section with Adjustable Accelerator Plate



Figure 4 - Wedge Wire Straining Elements

### STANDARD SCREEN MATERIALS

- 304 Stainless Steel
- 316L Stainless Steel
- Monel
- Other materials available upon request

### STRAINING ELEMENT SELECTION

The 700 Series Straining Element (Fig. 4) is an extremely rugged, single-piece unit available in a variety of standard and custom openings and materials.

Screen opening should be selected based on the amount of protection necessary and not on the smallest opening available. By specifying a smaller opening than needed, more debris will be retained and will subsequently result in longer cleaning durations and increased backwash fluid loss. Also, smaller than necessary screen openings will reduce open screen area and increase pressure loss.

The screen opening should be sized approximately one third (1/3) to one half (1/2) the largest size particle that can safely pass downstream. Example: A strainer protecting spray nozzles with a 1/16" orifice should be supplied with a 1/32" screen opening.

Slot Opening (inches)	Fraction Equivalent (inches) (mm)	Mesh Equivalent	Micron Equivalent	% Open Area
<b>Standard</b>				
0.003	(0.08)	200	76	9
0.006	(0.15)	100	152	16.5
0.010	(0.25)	50	254	17.5
0.015	1/64 (0.4)	40	381	24
0.020	(0.5)	35	508	30
0.032	1/32 (0.8)	20	813	40
0.062	1/16 (1.6)	10	1575	51
0.125	1/8 (3.2)	6	3175	67
0.187	3/16 (4.8)	4	4750	72
0.250	1/4 (6.4)	3	6350	78
Other slot openings are available upon request.				

### ADVANTAGES OF WEDGE WIRE STRAINING ELEMENT

- Maximum effective flow area and maximum operating efficiency are maintained throughout service life.
- Maintenance costs are reduced drastically due to reduced clogging and stapling of fibrous material.
- Long-lived straining element provides reduced operating costs over entire service life.
- Rigid element prevents flexing which can cause premature element failure.
- Efficient, effective debris collection at media/screen interface.

# Series 774 Automatic Skid Package



## Sequence Controller

### DESIGN AND CONSTRUCTION

The Fluid Engineering's Sequence Controller is designed with the Customers' specific requirements in mind. The Sequence Controller provides an automatic, effective backwashing cycle with a minimum loss of water.

The Fluid Engineering Sequence Controllers are constructed with state-of-the-art industrial type components, which permits replacing individual components without having to replace an entire circuit board. The industrial type components are more durable and reliable and adjustments can be made with ease (Fig. 5).

### MODES OF OPERATION

There are basically two modes of operation – intermittent and continuous. By turning the selector switch, the mode of operation can be selected.

### AUTOMATIC INTERMITTENT POSITION

With the selector switch in the "Auto" position, the drive motor will start and the backwash valve opens as determined by the adjustable cycle timer or by the differential pressure switch.

The differential pressure switch is normally factory set at 1 – 1½ psig over the anticipated clean pressure drop. Should a high differential pressure occur during the timed off period, the differential pressure switch will override the cycle timer and start or continue to backwash until the differential pressure is satisfied.

After the differential pressure has been satisfied, the strainer will continue to backwash for an additional 60 seconds (time delay relay).

The Fluid Engineering Automatic Self-Cleaning Strainer would start a backwash cycle based on the timed sequence selected on the adjustable cycle timer. The timed sequence should be determined by each installation and the conditions experienced. The adjustable cycle timer can be programmed from 15 minutes to a 10-hour cycle (off) and for 1 to 10 minutes duration (on). Adjustments can be made as conditions warrant them. The default factory settings for timers are 20-30 minutes OFF and 2-3 minutes ON.

### CONTINUOUS OPERATION

The selector switch is adjusted to "Manual" thus permitting the continuous mode. In the continuous mode, the Fluid Engineering Automatic Self-Cleaning Strainer will be backwashing continuously



Figure 5

with the backwash valve open and the drive motor running. This mode of operation may be necessary if the installation experiences high solid loadings.

In either mode of operation, the backwash assembly is specifically designed to rotate at 2 RPM to allow for effective backwashing in less time, thus decreasing the amount of backwash water lost.

### CONTROL PACKAGE

The Fluid Engineering Sequence Controller Control Package consists of:

- Control Panel with Nema 4 Enclosure
- Backwash Valve with Electric Operator
- Dual Element Differential Pressure Switch

### STANDARD FEATURES

- Enclosure – Nema 4
- Adjustable Cycle Timer
- Off-Delay Timer
- Motor Starters with Auxiliary contact and overload relay
- Selector Switch
- Indicating Lights
- Fuses
- Terminal Block

### OPTIONS

- 110 V, 230 V, 380 V, 460 V, 575 V
- 50 or 60 hertz
- Nema 4X (fiberglass or stainless steel), Nema 7 or 9 (explosion proof), Nema 12, Nema 3 enclosures
- Circuit breakers, disconnect switch, transformer
- Reset buttons
- Alarms
- PLC interface and/or pump interlock
- Extra contact and relays



# Series 774 Automatic Skid Package

SERIES 774  
PRESSURE DROP P.S.I. WITH 1/32" OR  
LARGER SCREEN OPENING

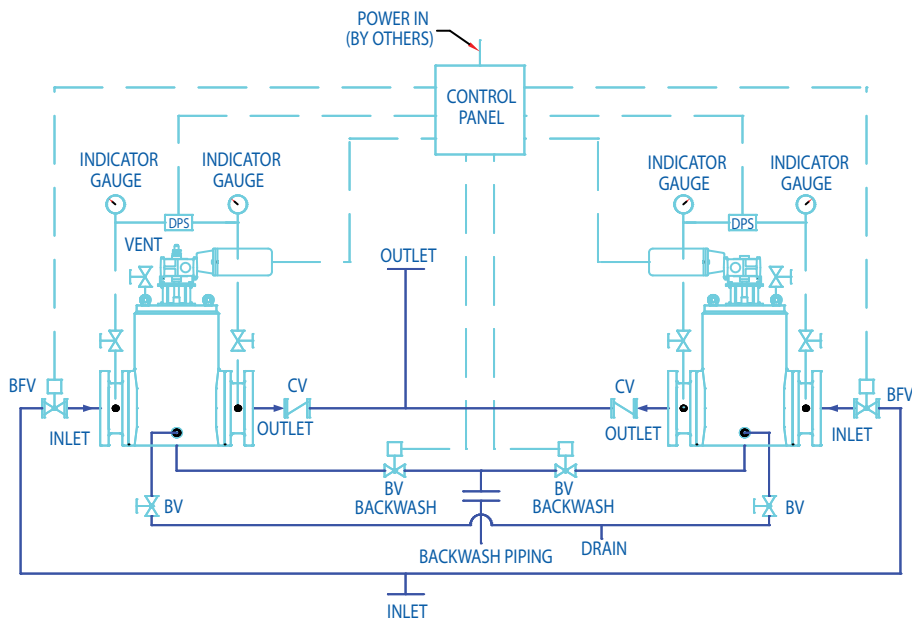
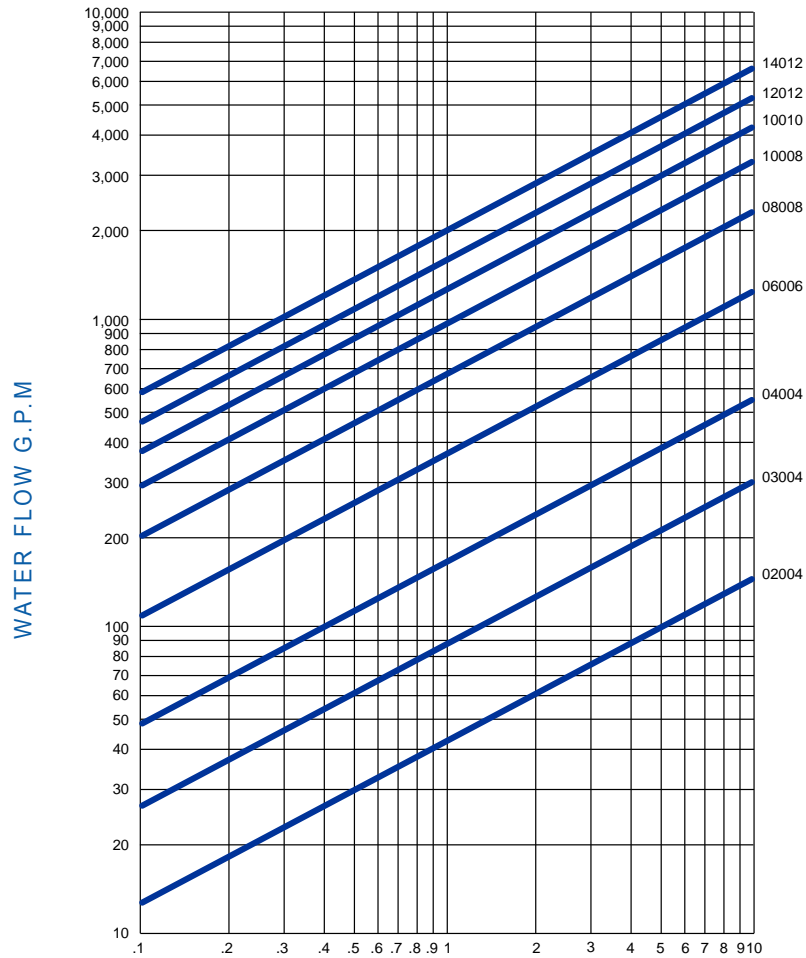

# Series 774 Automatic Skid Package

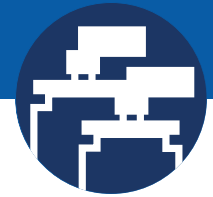

## Specifications

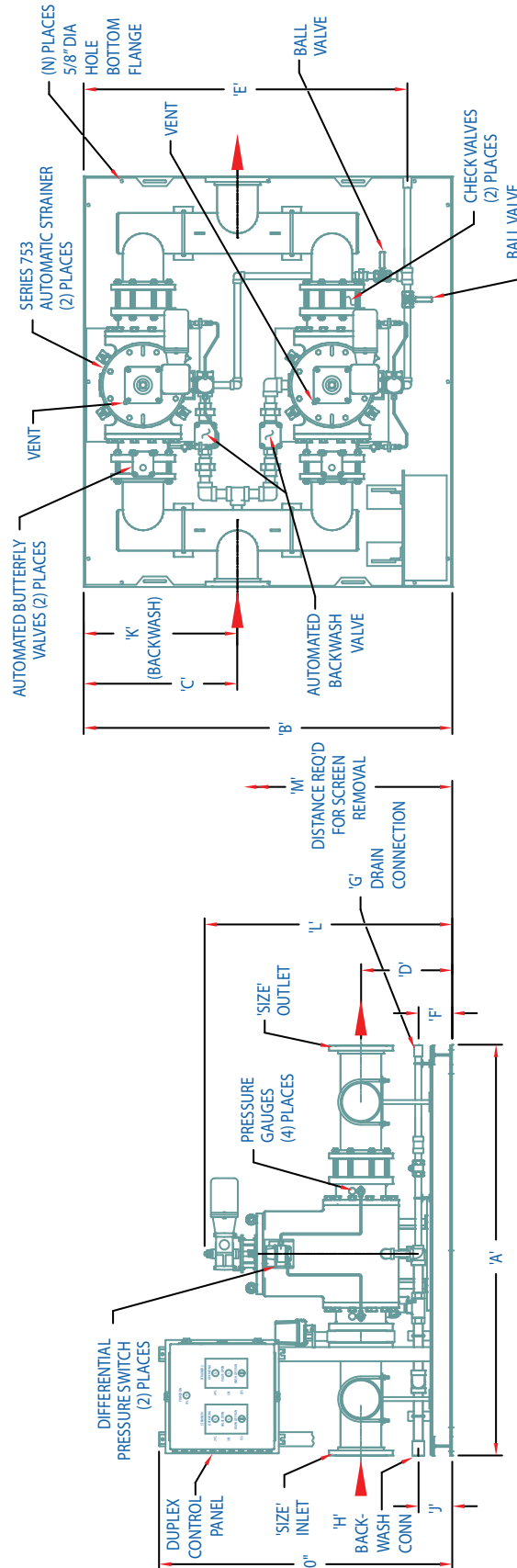

SIZE	A	B	C	D	E	F	G	H	J	K	L	M	N
INLET/	SKID	DEPTH	NOZZLE	NOZZLE	DRAIN	DRAIN	DRAIN	B.W.	B.W.	B.W.	STRAINER	SCREEN	MOUNTING
OUTLET	WIDTH	DEPTH	LOCATION	HEIGHT	LOCATION	HEIGHT	CONN	CONN	HEIGHT	LOCATION	HEIGHT	REMOVAL	HOLE
2"	60"	62"	23"	15-13/16"	49"	13-1/4"	1"	1"	8-1/2"	29"	42-1/2"	66"	4
51 mm	1524 mm	1575 mm	584 mm	402 mm	1245 mm	337 mm	25 mm	25 mm	216 mm	737 mm	1080 mm	1676 mm	
3"	60"	62"	23"	15-13/16"	49"	13-1/4"	1"	1"	8-1/2"	29"	42-1/2"	66"	4
76 mm	1524 mm	1575 mm	584 mm	402 mm	1245 mm	337 mm	25 mm	25 mm	216 mm	737 mm	1080 mm	1676 mm	
4"	60"	62"	23"	15-13/16"	49"	13-1/4"	1"	1"	8-1/2"	29"	42-1/2"	66"	4
102 mm	1524 mm	1575 mm	584 mm	402 mm	1245 mm	337 mm	25 mm	25 mm	216 mm	737 mm	1080 mm	1676 mm	
6"	60"	72"	29"	16-13/16"	66"	10-1/4"	1"	1-1/2"	7-1/4"	29"	44-1/2"	68"	6
152 mm	1524 mm	1829 mm	737 mm	427 mm	1676 mm	260 mm	25 mm	38 mm	184 mm	737 mm	1130 mm	1727 mm	
8"	86-1/2"	78"	32-1/2"	19-1/4"	68-1/2"	7-1/4"	1"	1-1/2"	7-1/8"	32-1/2"	53"	81"	6
203 mm	2197 mm	1981 mm	826 mm	489 mm	1740 mm	184 mm	25 mm	38 mm	18 mm	826 mm	1346 mm	2057 mm	
10"	102"	96"	45-1/2"	24-9/16"	92-1/2"	12-1/2"	1"	2"	10-1/4"	45-1/2"	96"	76"	8
254 mm	2591 mm	2438 mm	1156 mm	624 mm	2350 mm	318 mm	25 mm	51 mm	260 mm	1156 mm	2538 mm	1930 mm	
12"	102"	96"	45-1/2"	24-9/16"	92-1/2"	12-1/2"	1"	2"	10-1/4"	45-1/2"	96"	76"	8
305 mm	2591 mm	2438 mm	1156 mm	624 mm	2350 mm	318 mm	25 mm	51 mm	260 mm	1156 mm	2538 mm	1930 mm	
14"	102"	96"	45-1/2"	24-9/16"	92-1/2"	12-1/2"	1"	2"	10-1/4"	45-1/2"	96"	76"	8
356 mm	2591 mm	2438 mm	1156 mm	624 mm	2350 mm	318 mm	25 mm	51 mm	260 mm	1156 mm	2538 mm	1930 mm	

Other sizes and models available on application. Dimensions subject to change without notice, apply for certified drawings.

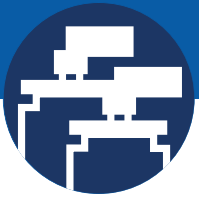

# Series 774 Automatic Skid Package

Fluid Engineering | 1432 Walnut St | Erie, PA 16502 USA  
PH 814.453.5014 | FAX 814.452.6573 | [www.fluideng.com](http://www.fluideng.com) | [sales@fluideng.com](mailto:sales@fluideng.com)

## Custom Design Skid Packages



### CUSTOMIZATION

Fluid Engineering offers flexible configuration for the Series 774 Automatic Skid Package. Various arrangements can be configured with Fluid Engineering's full line of patented automatic strainers.

### PROVEN ENGINEERING

Fluid Engineering (FE), a division of TM Industrial Supply, Inc., is an employee-owned engineering and manufacturing company that holds an ASME Section VIII, Division 1, Code "U" Stamp. FE develops and manufactures products for hundreds of commercial, industrial, and various other applications. FE holds numerous patents pertaining to the filtration of liquid and gas technologies.

