

Series 600 Bag Filters Single Bag Housing

The Series 600 are pressure vessels installed in a pipeline to remove unwanted solids from fluids. The Series 600 are used in applications where flow can be interrupted for bag replacement (duplex arrangements are available upon request).

The Series 600 are designed with .4 to .5 cu. ft. debris holding capacity that allows for a longer run time. Along with a large holding capacity, they can also be used for iron recovery by including our MagnaFilt Bag option. The incorporation of the swing bolt closure eliminates the use of any tools and also eliminates the need for nuts and bolts as in other designs in the market place.



STANDARD FEATURES:

- Offset Connections
- Swing Bolt Closure
- Standard Housing Materials are carbon steel, 304 stainless steel, or 316 stainless steel
- Inlet/Outlet Connections are ANSI Flanges or NPT
- Vent and Drain Connections are NPT
- Two 1/4" NPT Instrument Connections
- Viton Seals
- Design Working Pressure: 150 psig
- Design Working Temperature: 250°F
- Designed, manufactured, and tested generally in accordance with ASME Section VIII, Division 1 with welders qualified to Section IX

FILTER BAG DESIGN:

- Silicon-free thread used
- Grade 69 thread is used with a measured tensile strength of up to 15 pound per strand
- Three threads in our overlock stitch, and to rule out raveling, two additional threads in a true safety chain stitch are used.
- Materials:
 - * Polypropylene
 - * Polyester
 - * Nylons
 - * Nomex
 - * Oil Absorbent (Available In Singed or Plain Fabrics)

OPTIONS:

- ANSI flanges for vent and drain connections
- Support baskets are available in other materials, perforations, and meshes
- Other design pressures and temperatures are available upon request
- U-Stamp



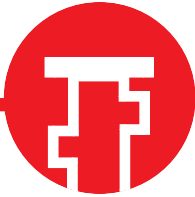
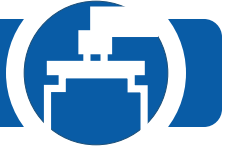

Series 602 Bag Filters Single Bag Housing

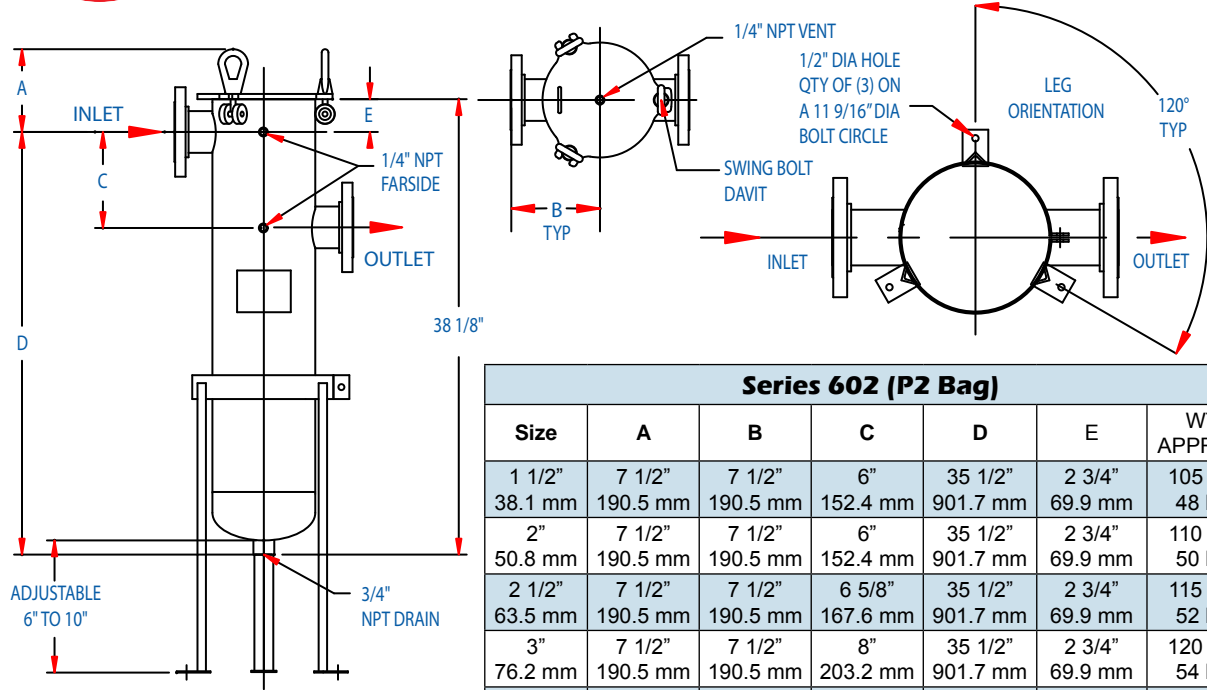

Series 602 (P2 Bag)						
Size	A	B	C	D	E	WT APPROX
1 1/2"	7 1/2"	7 1/2"	6"	35 1/2"	2 3/4"	105 lbs
38.1 mm	190.5 mm	190.5 mm	152.4 mm	901.7 mm	69.9 mm	48 kg
2"	7 1/2"	7 1/2"	6"	35 1/2"	2 3/4"	110 lbs
50.8 mm	190.5 mm	190.5 mm	152.4 mm	901.7 mm	69.9 mm	50 kg
2 1/2"	7 1/2"	7 1/2"	6 5/8"	35 1/2"	2 3/4"	115 lbs
63.5 mm	190.5 mm	190.5 mm	167.6 mm	901.7 mm	69.9 mm	52 kg
3"	7 1/2"	7 1/2"	8"	35 1/2"	2 3/4"	120 lbs
76.2 mm	190.5 mm	190.5 mm	203.2 mm	901.7 mm	69.9 mm	54 kg
4"	7 3/4"	8 5/8"	8"	35 1/4"	3"	135 lbs
101.6 mm	196.9 mm	219.1 mm	203.2 mm	895.4 mm	76.2 mm	61 kg

Note: Dimensions subject to change without notice. Apply for certified drawings. Contact us for dimensions and drawings



MagnaFilt Bag Option:

The MagnaFilt Bag is constructed with three pockets sewn into the side walls to house the encapsulated stainless steel magnetic assembly. The reason that three magnets assemblies are used is to increase the sphere of influence in the bag to capture the maximum amount of ferrous contaminate. The multi-polarity design attracts microscopic ferrous impurities along the entire length of the magnetic bars. Magnets are rare earth magnets which do not need replacing.

The MagnaFilt Bag comes in a range of sizes and materials for virtually any liquid-based applications



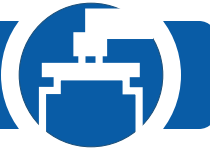

Series 603 & Series 603M Bag Filters Single Bag Housing

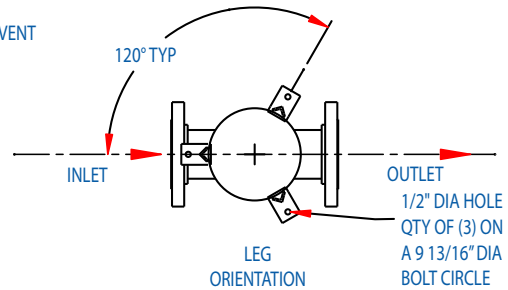
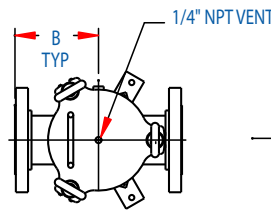
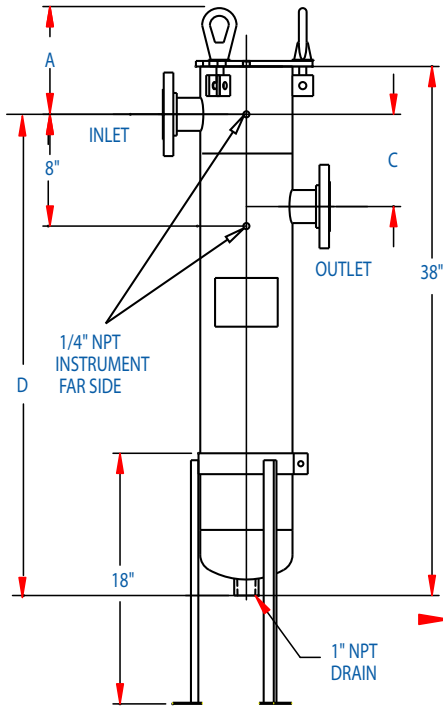
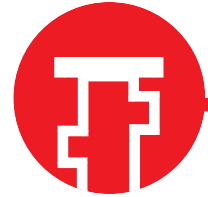

Series 603 (P9 Bag)					
Size	A	B	C	D	WT APPROX
1 1/2" 25.4 mm	7 1/2" 190.5 mm	6" 152.4 mm	4 3/4" 120.7 mm	34 9/16" 877.8 mm	80 lbs 36.3 kg
2" 50.8 mm	7 1/2" 190.5 mm	6" 152.4 mm	6 5/8" 168.3 mm	34 9/16" 877.8 mm	85 lbs 38.6 kg
2 1/2" 63.5 mm	7 1/2" 190.5 mm	6" 152.4 mm	6 5/8" 168.3 mm	34 9/16" 877.8 mm	88 lbs 39.9 kg
3" 72.6 mm	7 1/2" 190.5 mm	6" 152.4 mm	6 5/8" 168.3 mm	34 9/16" 877.8 mm	95 lbs 43.1 kg

Note: Dimensions subject to change without notice. Apply for certified drawings. Contact us for dimensions and drawings

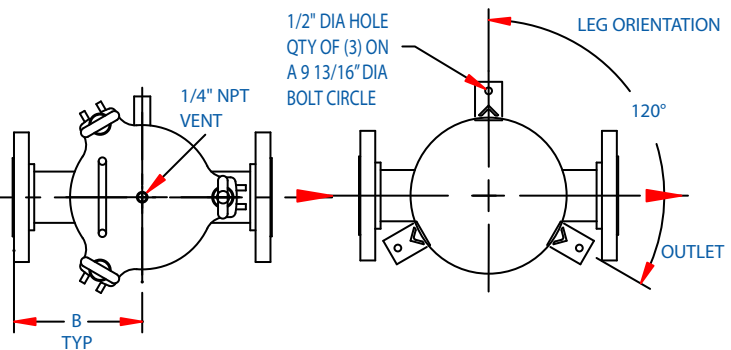
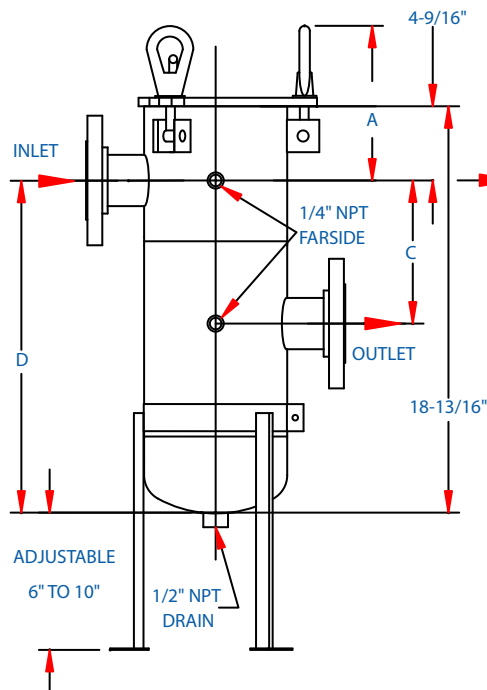

Series 603M (P4 Bag)					
Size	A	B	C	D	WT APPROX
1" 25.4 mm	7 1/2" 190.5 mm	5" 127 mm	3" 76.2 mm	14 1/4" 362 mm	58 lbs 26.3 kg
2" 50.8 mm	7 1/2" 190.5 mm	5" 127 mm	3" 76.2 mm	14 1/4" 362 mm	60 lbs 27.2 kg
2 1/2" 63.5 mm	7 1/2" 190.5 mm	5" 127 mm	3" 76.2 mm	14 1/4" 362 mm	65 lbs 29.5 kg

Note: Dimensions subject to change without notice. Apply for certified drawings. Contact us for dimensions and drawings

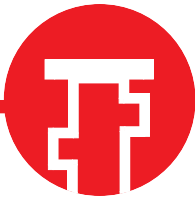
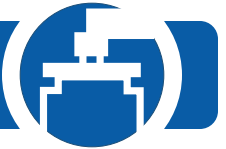

Series 604 & Series 605 Bag Filters Single Bag Housing

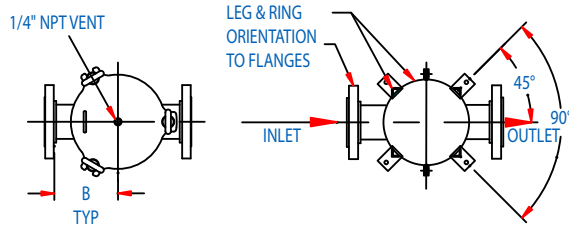
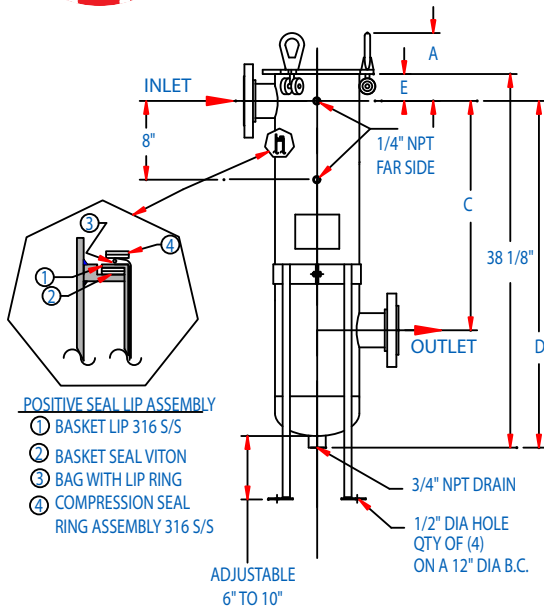

Series 604 (P2 Bag)						
Size	A	B	C	D	E	WT APPROX
2"	7 1/2"	7 1/2"	22 1/2"	35 1/2"	2 3/4"	95 lbs
50.8 mm	190.5 mm	190.5 mm	571.5 mm	901.7 mm	69.9 mm	43.1 kg
3"	7 1/2"	7 1/2"	22 1/2"	35 1/2"	2 3/4"	105 lbs
76.2 mm	190.5 mm	190.5 mm	571.5 mm	901.7 mm	69.9 mm	47.6 kg
4"	7 1/2"	8"	22 1/2"	35 1/2"	3"	115 lbs
102.6 mm	190.5 mm	203.2 mm	571.5 mm	901.7 mm	76.2 mm	52.1 kg

Note: Dimensions subject to change without notice. Apply for certified drawings. Contact us for dimensions and drawings

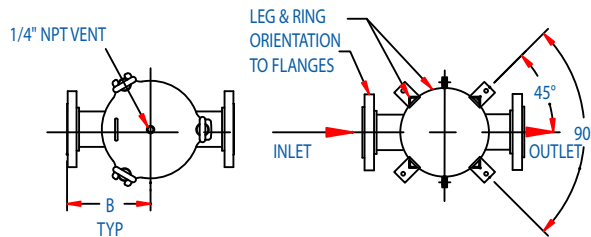
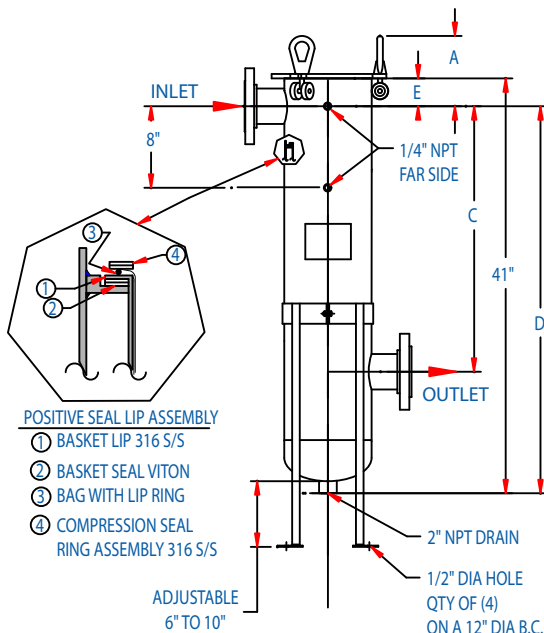

Series 605 (P2 Bag)						
Size	A	B	C	D	E	WT APPROX
2"	7 1/2"	8 1/4"	28 3/4"	38 3/8"	2 3/4"	95 lbs
50.8 mm	190.5 mm	209.6 mm	730.3 mm	974.7 mm	69.9 mm	43.1 kg
3"	7 1/2"	8 1/4"	28 3/4"	38 3/8"	2 3/4"	105 lbs
76.2 mm	190.5 mm	209.6 mm	730.3 mm	974.7 mm	69.9 mm	47.6 kg
4"	7 1/2"	9"	28 3/4"	38 3/8"	3"	115 lbs
102.6 mm	190.5 mm	228.6 mm	730.3 mm	974.7 mm	76.2 mm	52.1 kg

Note: Dimensions subject to change without notice. Apply for certified drawings. Contact us for dimensions and drawings

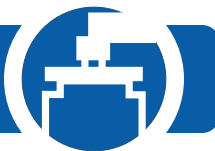

Model 626 Bag Filter Multi-Bag Housing



The Model 626 is a pressure vessel installed in a pipeline to remove unwanted solids from fluids. The Model 626 is used in applications where flow can be interrupted for bag replacement (duplex arrangements are available upon request).

The Model 626 is designed with .4 to .5 cu. ft. debris holding capacity (per bag) that allows for a longer run time. Along with a large holding capacity, they can also be used for iron recovery by including our MagnaFilt Bag option. The incorporation of the swing bolt closure eliminates the use of any tools and also eliminates the need for nuts and bolts as in other designs in the market place.

STANDARD FEATURES:

- Swing Bolt Closure
- Standard Housing Materials are carbon steel, 304 stainless steel, or 316 stainless steel
- Inlet/Outlet Connections are ANSI Flanges or NPT
- Vent and Drain Connections are NPT
- Two 1/4" NPT Instrument Connections
- Viton® Seals
- Design Working Pressure: 150 psig
- Design Working Temperature: 200°F
- Designed, manufactured, and tested generally in accordance with ASME Section VIII, Division 1 with welders qualified to Section IX

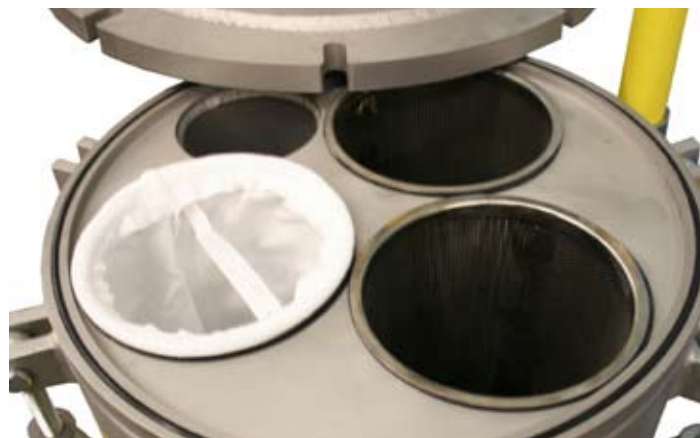

OPTIONS:

- ANSI flanges for vent and drain connections
- Support baskets are available in other materials, perforations, and meshes
- Other design pressures and temperatures are available upon request
- ASME SEC VIII Div 1 Code "U" Stamp

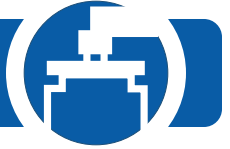

Model 626 Bag Filter Multi-Bag Housing

FILTER BAG DESIGN:

- Silicon-free thread used
- Grade 69 thread is used with a measured tensile strength of up to 15 pound per strand
- Three threads in our overlock stitch, and to rule out raveling, two additional threads in a true safety chain stitch are used.
- Materials:
 - * Polypropylene
 - * Polyester
 - * Nylons
 - * Nomex®
 - * Oil Absorbent
(Available In Singed or Plain Fabrics)

FILTER BAG NOTE:

Recommended MAXIMUM flow rates per bag:

1μ - 3μ	40 GPM
5μ - 10μ	80 GPM
15μ & up	100 GPM

Viscosity of liquids and debris loading will affect these flow rates.

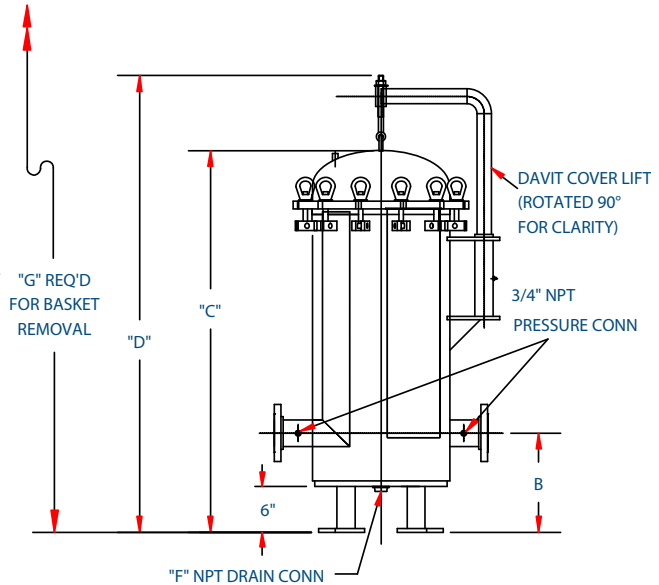
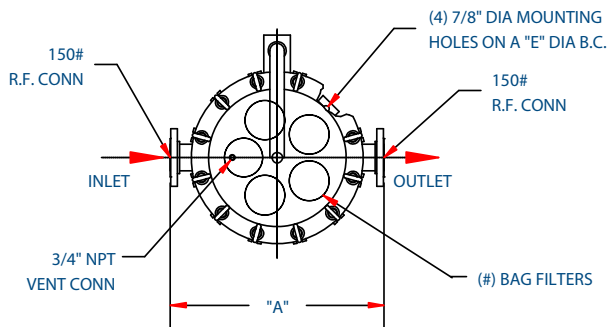

Model	# of Bags	Available Nozzle Size	A	B	C	D	E	F	G
626-XXX16-	2	2", 3", 4"	26" 660mm	13" 330mm	50" 1270mm	60" 1524mm	16" 406mm	1" NPT	74" 1880mm
626-XXX18-	3	2", 3", 4"	28" 711mm	13" 330mm	50" 1270mm	60" 1524mm	18" 457mm	1" NPT	74" 1880mm
626-XXX22-	4	3", 4", 6"	32" 813mm	13" 330mm	52" 1321mm	62" 1600mm	22" 610mm	1" NPT	76" 1930mm
626-XXX24-	6	4", 6", 8"	34" 864mm	13" 330mm	53" 1346mm	63" 1600mm	24" 610mm	1-1/2" NPT	77" 1956mm
626-XXX30-	8	4", 6", 8"	40" 1016mm	13" 330mm	55" 1397mm	65" 1651mm	30" 762mm	1-1/2" NPT	79" 2007mm

Note: "-XXX" denotes nozzle size: -020 (2"), -030 (3"), -040 (4"), -060 (6"), -080 (8").

Dimensions subject to change without notice. Apply for certified drawings. Contact us for custom dimensions and drawings.