

Cascading Strainer Model 290 Separate Solids from Liquids

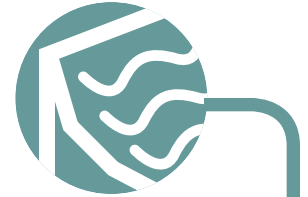

Separation 100 to 2000 micron
Available with or without debris catcher
Construction:

Body: Carbon steel with epoxy paint
Optional 304SS or 316 SS

Screen: Wedgewire 316L SS

Stand: Carbon steel with epoxy paint
Optional 304SS or 316 SS

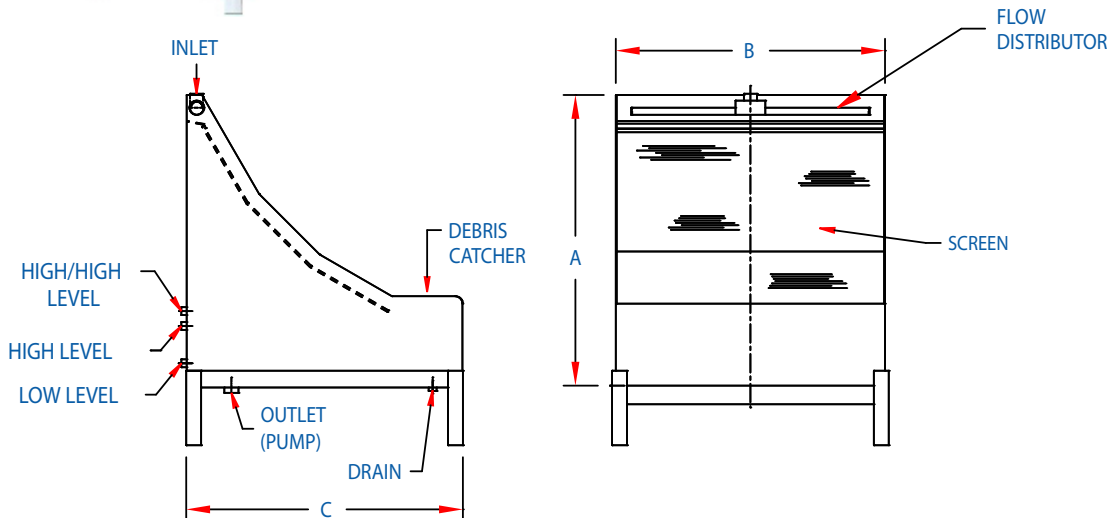

Model No.	A (in.)	B (in.)	C (in.)	INLET	OUTLET	DRAIN	FLOW (MAX)
290-010025	39" 991 mm	37" 940 mm	38" 966 mm	1" NPT	1 1/4" NPT	1/2"	25 GPM
290-020100	71" 1804 mm	37" 940 mm	67" 1702 mm	2" NPT	2" NPT	1"	100 GPM
290-030250	77" 1956 mm	73" 1855 mm	67" 1702 mm	3" - 150# FLG	3" - 150# FLG	1"	250 GPM
290-040400	77" 1956 mm	73" 1855 mm	67" 1702 mm	4" - 150# FLG	4" - 150# FLG	1"	400 GPM

Dimensions subject to change without notice, apply for certified drawings.

"Engineered Products for Demanding Applications, Performance, and Service"

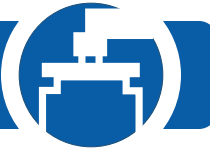

Model 291 Static Gravity Strainer

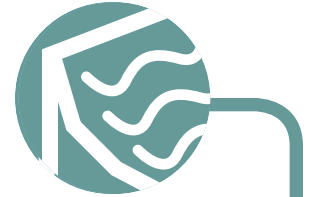

Product Description

Model 291 Static Gravity straining elements are triple sloped design, slotted, wedgewire screen with multiple slot widths oriented horizontally across the direction of flow. The decks are positioned at a steeply sloped angle providing an effective stripping of liquid and allowing the solids to slide off the discharge lip. These are typically used when the solids are easily separated from the liquid and where the separated solids slide easily.

Method of Operation

Wastewater or slurry is gravity fed or pumped to the headbox. The wastewater then drops down onto a triple sloped screen design that orients the flow tangentially onto the screen surface. The liquid passes through the openings in the wedgewire to a drainage area, located under the screen, and the solids slide down the surface of the screen to the discharge lip. Solids greater than the opening are retained on the screen surface where they build kinetic energy and roll downward off the screen to reuse or disposal. With free drainage material, most of the free fluid is removed in one pass.

Features

- * Triple sloped screen design
- * Carbon steel with epoxy paint body and stand construction
- * 316 stainless steel wedgewire screen
- * Tapered flow design
- * Full enclosure with hinged access doors
- * Low maintenance costs
- * No motors or moving parts



Model 290 gravity strainer shown

Options

- * 304 or 316 stainless steel body and stand construction
- * Range of wedgewire designs
- * Cleaning spray nozzles

Applications

Wet Corn Milling

- * Corn Dewatering
- * Slurry Dewatering
- * Effluent Pre-treatment

Pulp and Paper

- * Broke Thickening
- * Clarifying chip washer effluent
- * Thickening pressure screen rejects

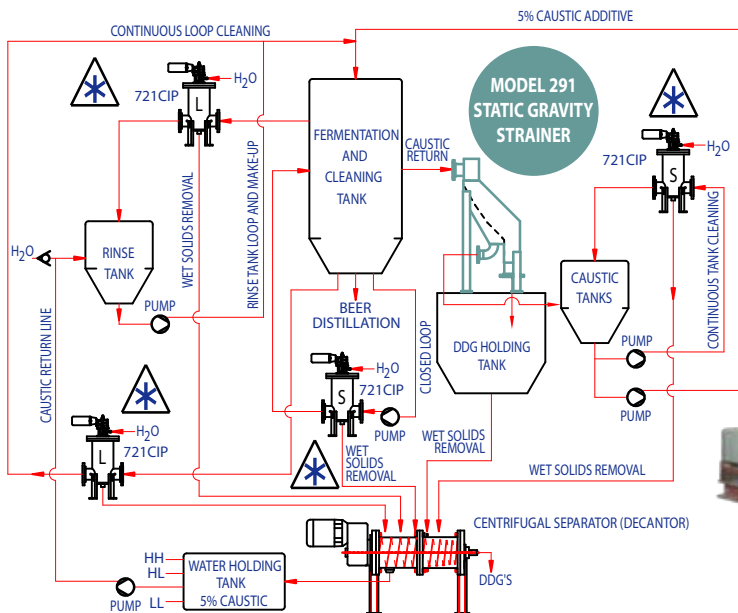

Model 290 gravity strainer in a filtration package

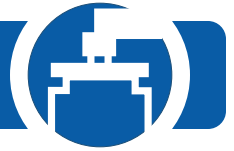

Model 291 Static Gravity Strainer

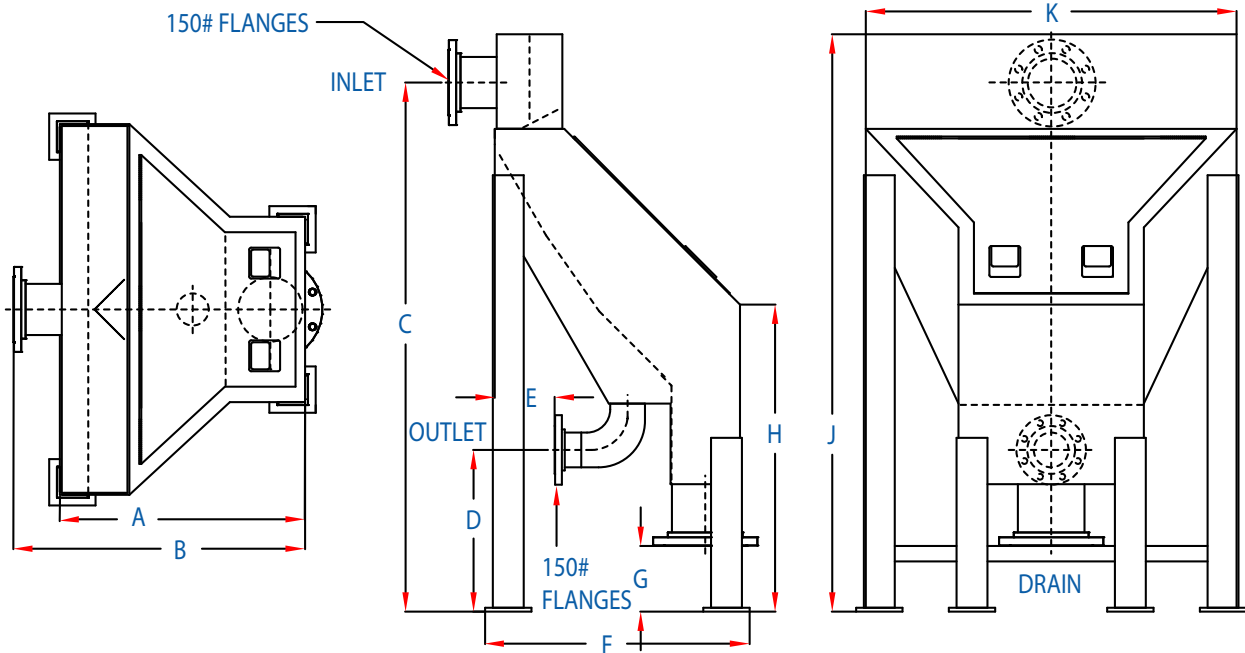

I (INLET)	O (OUTLET)	DRAIN	A	B	C	D	E	F	G	H	J	K	FLOW ¹
2" 50 mm	2" 50 mm	6" 150 mm	28 1/4" 717.6 mm	37 3/4" 958.9 mm	68 1/2" 1739.9 mm	24" 609.6 mm	7 3/4" 196.9 mm	34 1/4" 870.0 mm	8 1/2" 215.9 mm	39 3/4" 1009.7 mm	74 3/4" 1898.7 mm	48" 1219.2 mm	100 GPM
4" 100 mm	3" 75 mm	6" 150 mm	28 1/4" 717.6 mm	37 3/4" 958.9 mm	68 1/2" 1739.9 mm	22.5" 571.5 mm	7 3/4" 196.9 mm	34 1/4" 870.0 mm	8 1/2" 215.9 mm	39 3/4" 1009.7 mm	74 3/4" 1898.7 mm	48" 1219.2 mm	315 GPM
6" 150 mm	4" 100 mm	8" 200 mm	27 1/4" 692.2 mm	37 3/4" 958.9 mm	68 1/2" 1739.9 mm	21" 533.4 mm	7 3/4" 196.9 mm	34 1/4" 870.0 mm	8 1/2" 215.9 mm	39 3/4" 1009.7 mm	74 3/4" 1898.7 mm	48" 1219.2 mm	540 GPM
8" 200 mm	6" 150 mm	10" 250 mm	43 1/4" 1098.6 mm	54.3/4" 1390.7 mm	92 1/4" 2344.7 mm	17 1/2" 444.5 mm	11 3/4" 298.5 mm	51 1/4" 1301.8 mm	8 1/2" 215.9 mm	44 1/4" 1125.5 mm	100 5/8" 2554.3 mm	48" 1219.2 mm	780 GPM
10" 250 mm	8" 200 mm	12" 300 mm	42 1/4" 1071.6 mm	54.3/4" 1390.7 mm	92 1/4" 2344.7 mm	14 1/2" 368.3 mm	11 3/4" 298.5 mm	51 1/4" 1301.8 mm	8 1/2" 215.9 mm	44 1/4" 1125.5 mm	100 5/8" 2554.3 mm	48" 1219.2 mm	985 GPM

Notes: Dimensions subject to change without notice. Apply for certified drawings.

¹Flow is based on a .078 (2 mm) slot.

"Engineered Products for Demanding Applications, Performance, and Service"